

1. O-ring Standards

The O-ring has become the world's most popular and versatile seal due to its simple shape, low space requirements, and its availability in a vast selection of sizes and compounds to meet every industrial requirement.

The ERIKS O-ring manual is intended as a guide to assist in the selection of the best O-ring out of the correct rubber compound in the right application for engineers, purchasers, and other users of O-rings. We hope that you find it both convenient and helpful.

This book contains detailed information concerning elastomeric compounds, installation information, sizing tables, and groove dimensions.

The dimension tables represent standards available from ERIKS inventories.

These O-rings are manufactured in accordance with a variety of standards for each country:

- AS 568A USA
- BS 1806 England
- DIN 3771 Germany
- SMS 1586 Sweden
- AFNOR 47501 France
- JIS B2401 Japan
- ISO 3601 International

There are also military material specifications per a "MIL" designation and aerospace material specifications per a "AMS" designation.

Our standard program covers 30.000 sizes in a large variety of rubber compounds for your specific purpose. Technical data and advice are available at any time. Many non-standard sizes are available upon request.

Please contact your ERIKS representative.

Our qualified staff guarantees excellent service. It's our goal to be your partner.

2. O-ring Sealing Principles

O-rings are bi-directional seals, circular in shape and cross section. O-rings are generally made of an elastomeric material, but may be made of other materials such as PTFE or metal. This handbook deals entirely with elastomeric O-rings and PTFE encapsulated elastomeric O-rings.

An O-ring seals through the deformation of the seal material by installation and media pressure to close off the gap between mating components.

Higher system pressures can cause deformation through the gap, known as extrusion, resulting in seal failure. Choosing a harder seal material or installing back-up rings to support the O-ring may alleviate this problem.

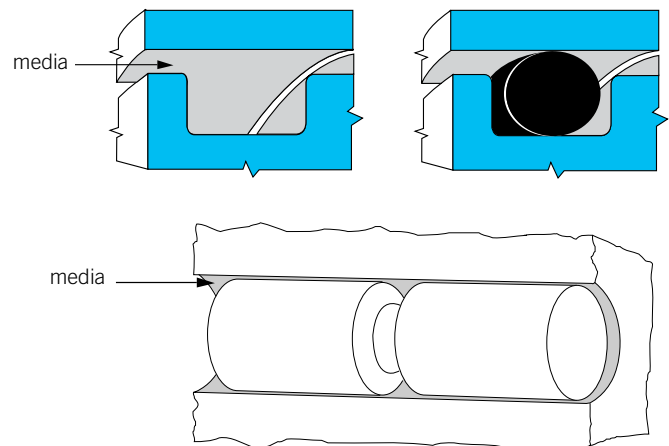

ERIKS O-ring is available in a variety of elastomeric compounds.

When you specify an O-ring we need to know the inside diameter (I.D.), the cross section diameter (W), and the compound (elastomer material) from which the O-ring is to be made.

All sealing applications fall into one of two categories - those in which the seal or sealed surface moves, and those in which the seal is stationary.

ID= O-ring inside diameter
w= O-ring cross section

