

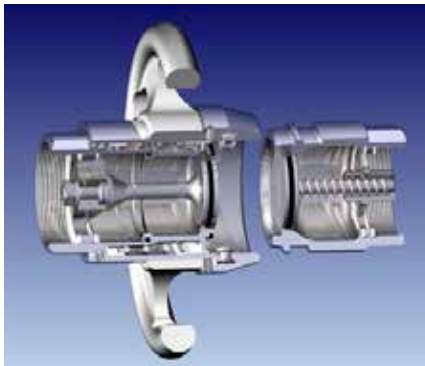

Customer : Oil services company
Product group : O-rings
Market : Oil and Gas
Application : O-rings

ERIKS OFFERS CUSTOMER FLEXIBILITY IN THE PURCHASE OF MISSION CRITICAL PARTS

Loading arm seals for oil services company



CHALLENGE

A leading oil services company that designs, manufactures and sells a full range of ambient and cryogenic marine loading arms worldwide were concerned with their lack of technical support from their current seal supplier.

The company had always purchased seals for their loading arms from the same supplier but felt vulnerable commercially and technically if the supplier discontinued supply for any reason. They began to search for additional suppliers that could meet their requirements for these mission critical parts.

SOLUTION

ERIKS was selected to be the additional supplier of Viton® GF V-Rings after offering a technical and commercial alternative to 3 sizes. This material allows the end user to transfer a wide range of fluids from marine tankers through the loading arms to onshore storage tanks and visa-versa.

OTHER BENEFITS

- Flexibility to purchase

FURTHER COMMENTS

The customer was delighted with ERIKS' application and technical knowhow. By focusing on the design of a suitable alternative sealing solution the customer now has the comfort of not being "locked" into a sole supply situation and has the flexibility to purchase further seals from ERIKS.